

VKO Series

The compact axial inline fan available in three sizes.

IPX4
Rated

Low
Noise

European
Motor

2
Year

2 year
replacement
warranty

fanco

100: EXVUVK01
125: EXVUVK02
150: EXVUVK03

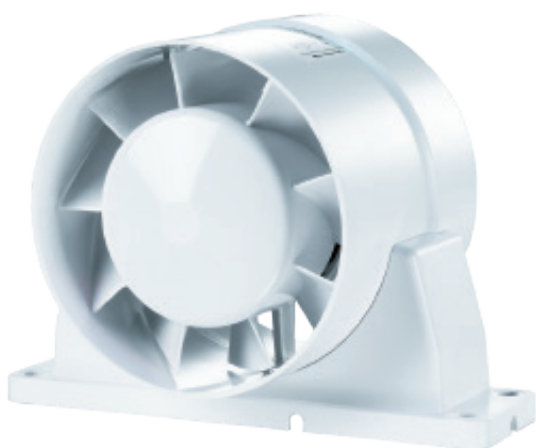

MODEL	COLOUR
100	
125	
150	

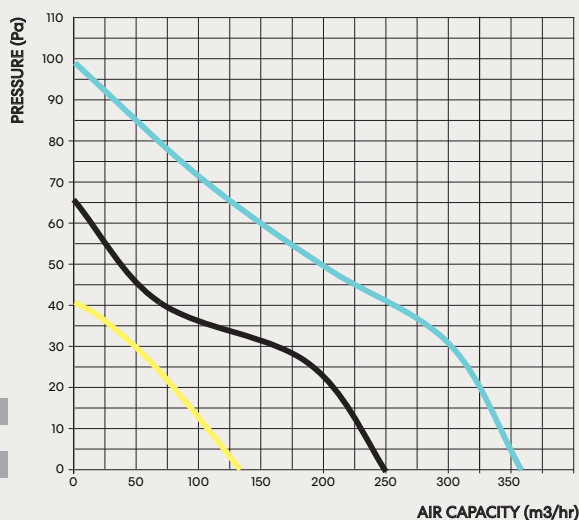

	100	125	150
Voltage	220 - 240	220 - 240	220 - 240
Current (A)	0.1	0.105	0.13
Power (w)	16	24	29
Noise Level dB(A)	38	39	44
Capacity (m ³ /hr)	135	243	358
Capacity (l/s)	37.53	67.55	99.52
Capacity (CFM)	79.51	143.12	210.86
Duct Size (mm)	100	125	150

Maximum temperature of transferred air 40°. The fan is designed for indoor application with the ambient temperature ranging from +1 °C up to +40 °C and relative humidity up to 80 %.

Dimensions (mm)

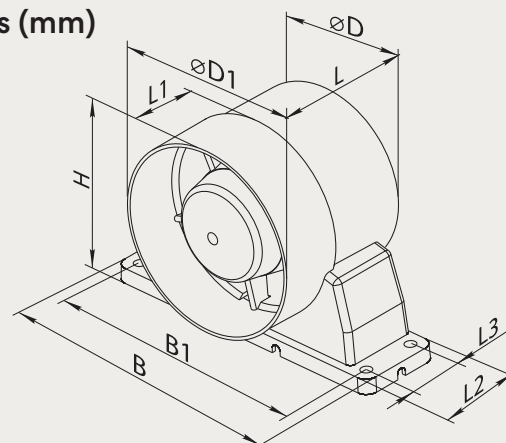

Model	D	D1	L	L1	H	B	B1	L2	L3
100	100	104	91	31	114	160	144	45	29
125	125	129	93	31	139	185	169	45	29
150	150	154	108	46	163	200	184	45	29