

TT Silent Series

The premium mixflow inline exhaust fan engineered to operate quietly.

IPX4
Rated

Low
Noise

European
Motor

2
Year

2 year
replacement
warranty

fanco

150: EXVUTTS150RV
200: EXVUTTS200RV

RV models include lead & plug +
2 position speed switch

250: EXVUTTS250
315: EXVUTTS315

Larger models
require hardwiring

The external casing
is made from polymer
coated steel. The housing
has an internal heat and
sound insulating layer with
50mm mineral wool.

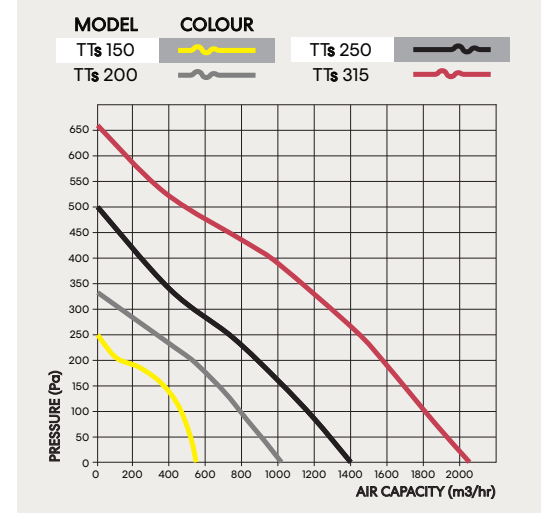

	150 RV Low / High	200 RV Low / High	250 Low / High	315 Low / High
Voltage	230	230	230	230
Current (A)	0.20 / 0.23	0.35 / 0.49	0.54 / 0.79	1.0 / 1.42
Power (w)	45 / 52	178 / 110	125 / 177	230 / 320
Noise Level dB(A)	26 / 33	31 / 36	34 / 38	36 / 40
Capacity (m ³ /hr)	405 / 555	810 / 1020	1110 / 1400	1570 / 2050
Capacity (l/s)	113 / 154	225 / 284	308 / 389	436 / 569
Capacity (CFM)	239 / 327	477 / 601	653 / 824	924 / 1207
Duct Size (mm)	150	200	250	315

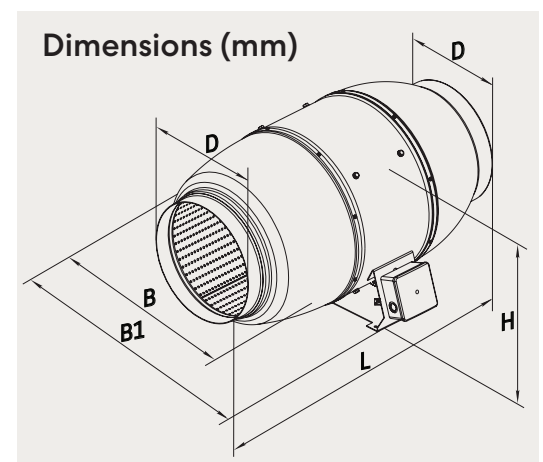

Model	D	B	B1	L	H
150	147	247	274	580	260
200	198	293	386	550	295
250	248	358	445	658	360
315	313	432	520	780	434

Maximum temperature of transferred air 60°. The fan is designed for indoor application with the ambient temperature ranging from +1 °C up to +40 °C and relative humidity up to 80 %.