

# Luna Series

A modern exhaust fan with a whisper quiet ball bearing motor designed to ensure longevity.

High Airflow

Low Noise

DIY Install

2 Year

2 year replacement warranty

fanco

Luna PRO 200:

ECFCL23W

Luna Quiet Boost 250:

ECFCL34W



	Luna 200	Luna 250
Voltage	240	240
Current (A)	0.113	0.146
Power (w)	25	42
Noise Level dB(A)	39.7	< 45
Capacity (m3/hr)	270	400
Capacity (l/s)	75	111.11
Capacity (CFM)	158.91	235.43
Duct Size (mm)	150	150

## Dimensions (mm)

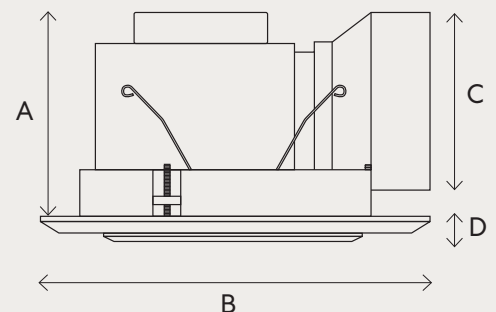

The Luna range is a high quality modern ceiling exhaust fan that can be connected to 150mm ducting. The Luna comes with a built in backdraft shutter and is available in two sizes. The fan comes with a lead and plug for easy DIY installation.

Model	A	B	C	D	Cutout
200	194	270	150	28	240
250	194	325	150	28	290

Minimum install depth on both models 220mm