

Hybrid Series

A contemporary high performance exhaust fan with a whisper quiet ball bearing motor that maintains quietness and is designed to ensure longevity.

High Airflow

Low Noise

DIY Install

2 Year

2 year replacement warranty

Hybrid 250 Side Ducted Motor: ECVUHBM10

Round Matte Black Grille: EAVUHB10RMBCOVER
 Round White Grille: EAVUHB10RWCOVER
 Square Matte Black Grille: EAVUHB10SQMBCOVER
 Square White Grille: EAVUHB10SQWCOVER
 Round White Grille LED: EAVUHB10RWCOVERLED
 Square White Grille LED: EAVUHB10SQWCOVERLED



Round Matte Black



Round White



Square Matte Black

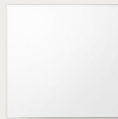

Square White



Round White LED



Square White LED



	Hybrid 250
Voltage	220-240
Current (A)	0.25
Power (w)	57
Noise Level dB(A)	36
Capacity (m3/hr)	482
Capacity (l/s)	133.89
Capacity (CFM)	283.70
LED Light Power (w)	12
Light Lumens	1000
Light Colour Temperature	Tri-Colour 3000-6000
Duct Size (mm)	150

Dimensions (mm)

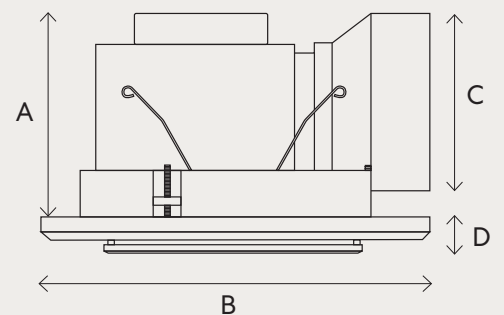

Model	A	B	C	D	Cutout
250	198	ø330	ø148	38	300

Minimum install depth on both models 220mm

The Hybrid range is a high quality modern ceiling exhaust fan that can be connected to 150mm ducting. The Hybrid comes with a built in backdraft shutter and is available with either a round or square fascia. The fan comes with a lead and plug for easy DIY installation.



Hybrid Pressure Curve

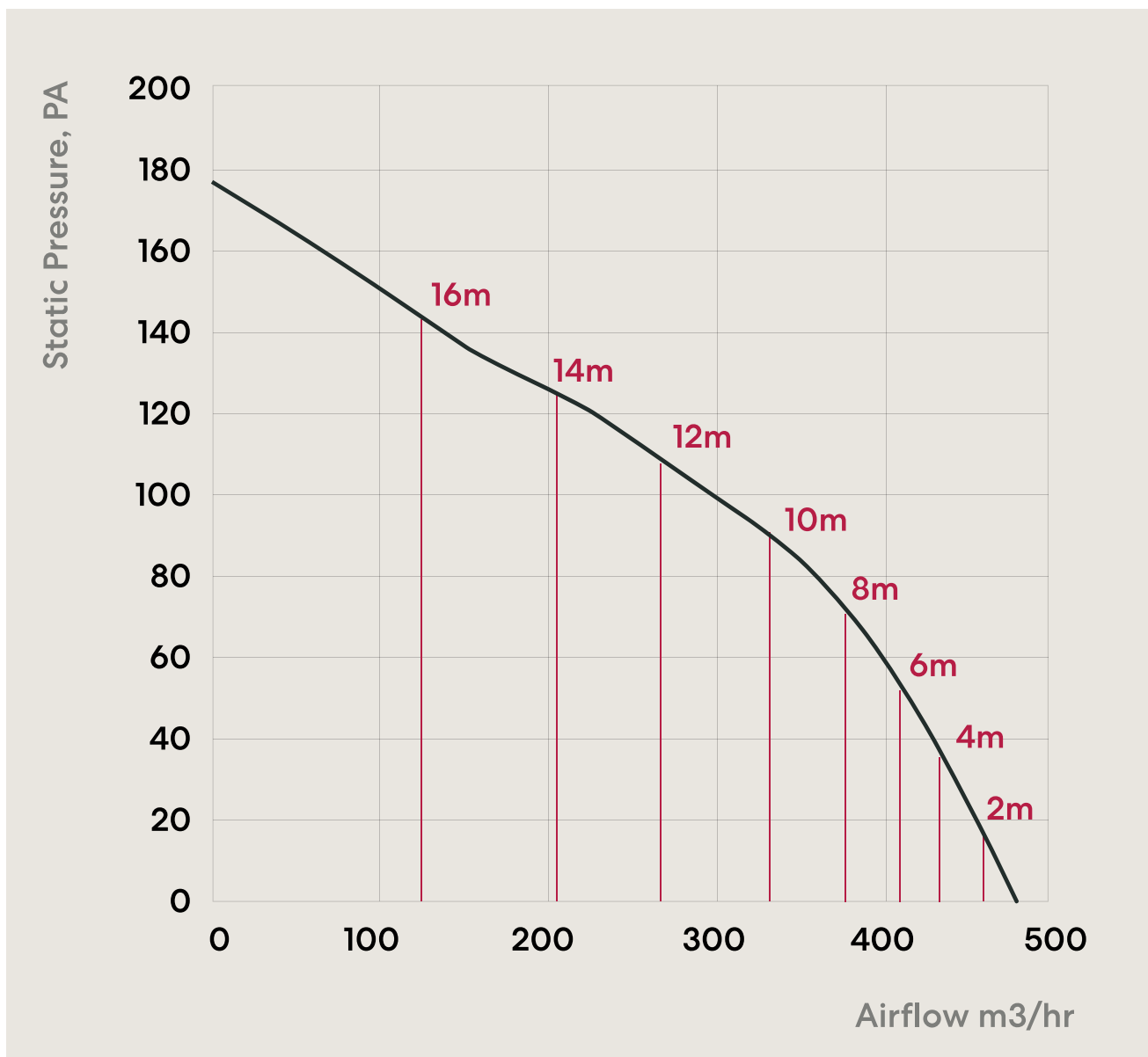

Explanation:

This product has been engineered to perform well with longer than normal lengths of ducting. As you can see from the above pressure curve, the fan maintains its extraction rate reasonably well up to about 8-10 metres of 150mm diameter ducting. Keep in mind however, that this is based on straight lengths and any bends or twists, will further contribute to pressure resistance and impact overall performance.