

VCN

Centrifugal

Installation Manual

fanco 

Before installing your new Fanco exhaust fan, it is important that you read and follow these instructions prior to installation, even if you feel you are quite familiar with this type of product. Please keep this document handy for future reference as it contains servicing and maintenance requirements.

WARNING

Disconnect the fan from power mains prior to any connection, servicing and repair operations.

Mounting and maintenance are allowed for duly qualified electricians with valid electrical work permit for electric operations at the units up to 1000V after careful study of the present user's manual.

The single-phase power mains must comply with the acting local electrical norms and standards.

The fixed electrical wiring must be equipped with an automatic circuit breaker. The fan must be connected to power mains through an automatic circuit breaker QF integrated into the fixed wiring system with the gap between the breaker contacts on all poles not less than 3 mm.

Check the fan for any visible damages of the impeller and the casing before starting installation.

The casing internals must be free of any foreign objects which can damage the impeller blades.

Misuse of the device or any unauthorized modification is not allowed.

The fan is not to be used by children and persons with reduced physical, mental or sensory capacities, without proper practical experience or expertise, unless they are controlled or instructed on the product operation by the person(s) responsible for their safety.

Do not leave children unattended and do not let them play with the product.

Take steps to prevent ingress of smoke, carbon monoxide and other combustion products into the room through open chimney flues or other fire-protection devices. Sufficient air supply must be provided for proper combustion and exhaust of gases through the chimney of fuel burning equipment to prevent back drafting.

Transporting medium must not contain any dust or other solid impurities, sticky substances or fibrous materials.

Do not use the fan in the environment containing hazardous or explosive materials and vapours, i.e. spirits, gasoline, insecticides, etc.

Do not close or block the fan intake or extract vents in order to ensure the most effective air passage.

Do not sit on the fan and do not put objects on the fan.

Fulfil the requirements stated in this user's manual to ensure long service life of the product.

Recycle at the end of the service life.

Do not dispose the product with unsorted municipal trash.

The VCN exhaust series described in this user's manual is a centrifugal external wall exhaust fan designed to supply and exhaust ventilation in rooms requiring high pressure and powerful airflow.

DELIVERY SET

1. Fan: 1 piece
2. Dowel and screws: 4 pieces
3. User's manual
4. Packing box

SHORT DESCRIPTION

The product described here is designed for extracting ventilation in living spaces such as offices, shops, garages, kitchens, bathrooms and other residential and public premises.

The fan is designed for top installation at ventilation shaft outlets.

The fan is made from metal.

The fan is equipped with a ball bearing motor.

The fan is designed for connection to Ø 125mm, 150mm and 200mm air ducts.

Due to constant improvements the design of some models may slightly differ from those ones described in this manual.

OPERATION RULES

The fan is designed for connection to AC 220-240 V, 50 Hz power mains.

Air flow direction in the system must match the pointer direction on the fan casing.

Ingress protection rating against access to hazardous parts and water ingress: IPX4

The minimum transported temperature for this fan is -15°C. The fan is suitable for short-term air transportation at a temperature reaching -30°C. The maximum transported temperature for this fan is +50°C.

The fan requires no grounding.

MOUNTING

The fan is designed for top mounting as shown below.

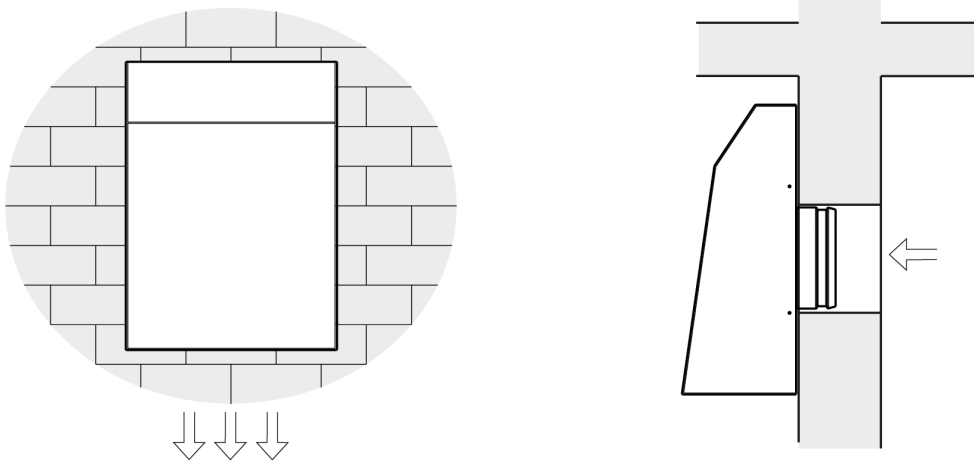

STEP 1 - Cut off power supply and make preparations in the room to install a fan.

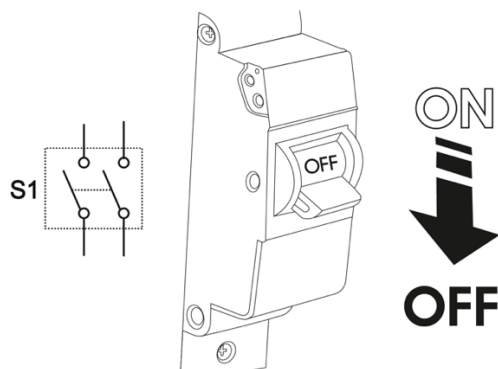

STEP 2 - To install the fan on the wall remove the self-tapping screws and remove the cover.

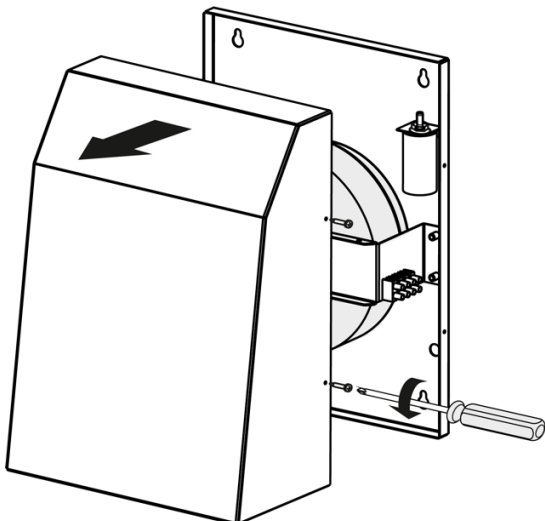

STEP 3 - Drill the holes for the dowels in compliance with the mounting seats on the fan casing and install the fan with screws. The power cable must be routed through the screwed cable gland.

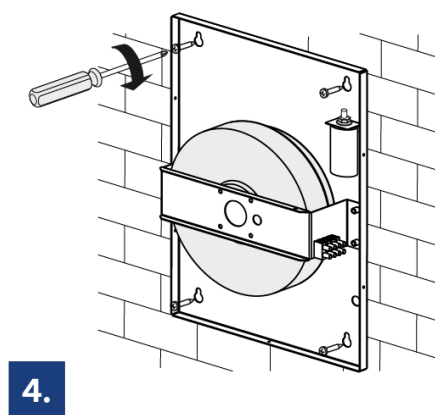
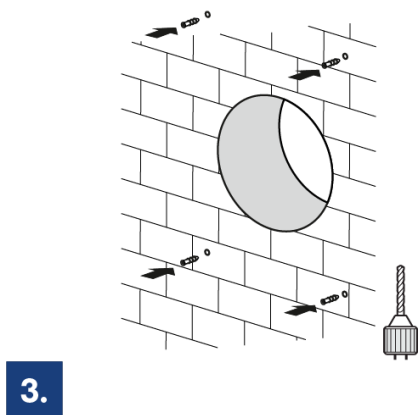
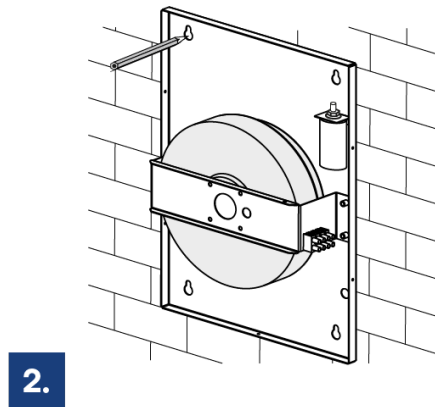
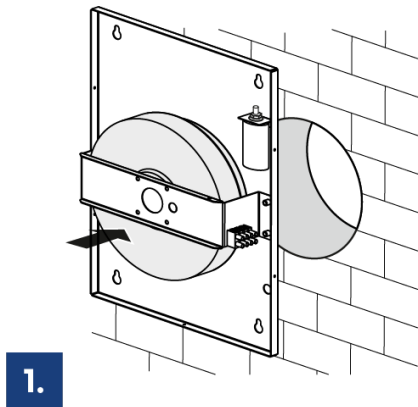

STEP 4 - Connect the fan to single-phase power mains through the automatic circuit breaker integrated into the fixed power mains. Cut power supply off prior to wireworks. The contact gap on all poles must be at least 3 mm.

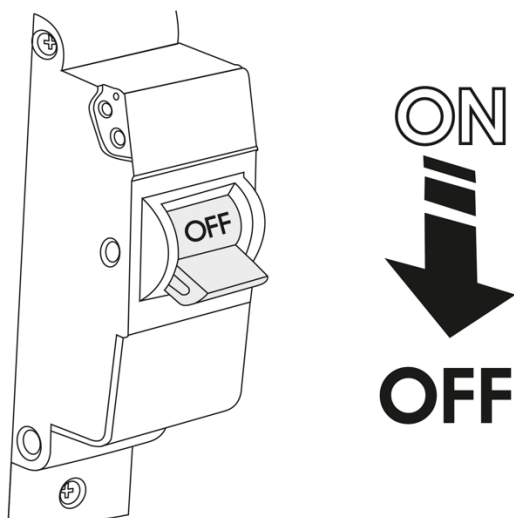

STEP 5 – Connect the power cable to terminal block 8 by following the wiring diagram.

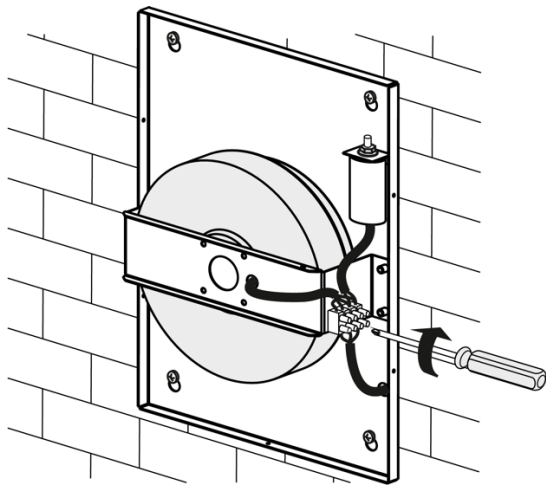

TERMINAL DESIGNATION KEYS AT WIRING DIAGRAMS:

L - phase (only for 220-240 V power mains)

N - 0 (only for 220-240 V power mains)

S1 - external switch

WIRING DIAGRAM

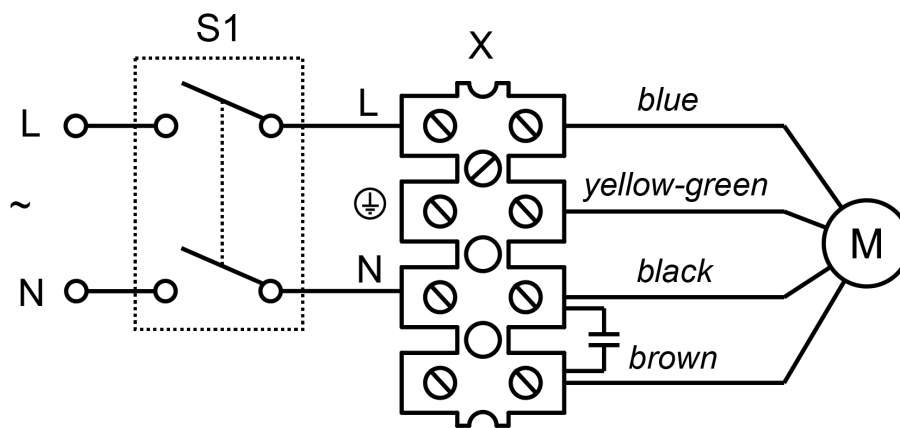

STEP 6 – Cover the fan and secure the cover using the self-tapping screws.

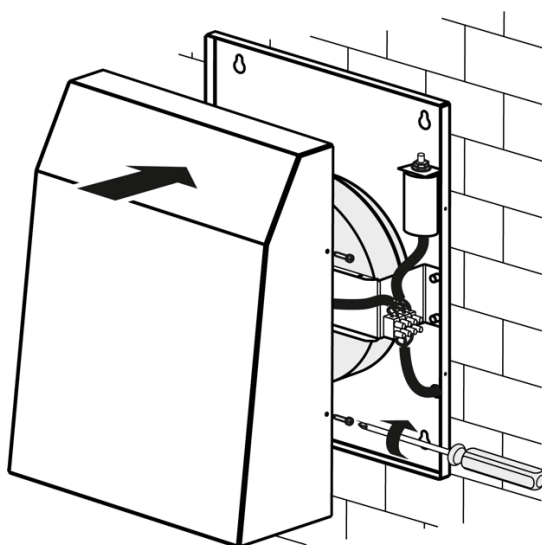

STEP 7 – Turn on mains power.

MAINTENANCE

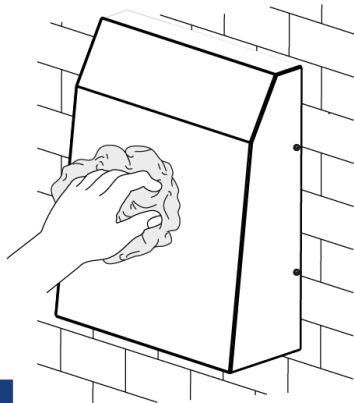

1.

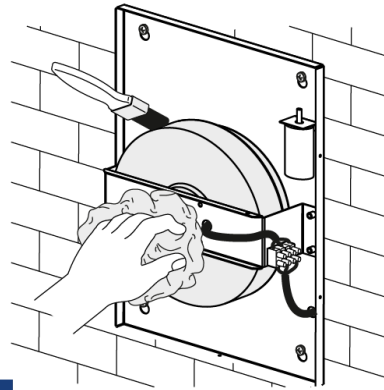

2.

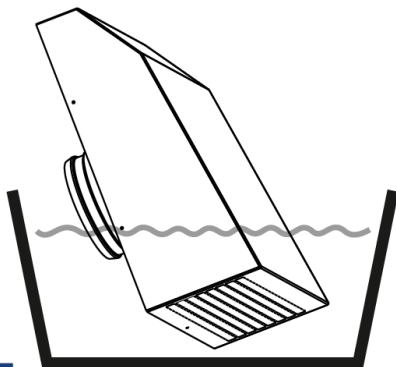

3.

The product surfaces must be regularly cleaned from dirt and dust. Cut off power supply prior to any maintenance operations. Use a soft cloth or compressed air to remove external dust (See Step 1). To clean internal surfaces, remove the front cover. The filter prevents the fan soiling and reduces the cleaning periodicity. Thoroughly clean the impeller blades every 6 months using a damp cloth soaked in mild detergent and water (Step 2). After cleaning the impeller mount the fan cover back on, tighten the screws and connect the fan to power supply. For cleaning use a soft cloth or brush and mild detergent water solution.

Avoid water dripping on the electric components. Wipe the surfaces dry after cleaning.

STORAGE REGULATIONS

Transport the product by any transportation vehicle in the manufacturer's original package.

Store the delivered product in the manufacturer's original packing box in a dry ventilated premise with the temperature range from +5°C up to + 40°C and relative humidity less than 80% at +20°C.

The storage environment must not contain dust, acid or alkali vapours that may cause corrosion of the product parts.

fanco●