

# VKM Series

Centrifugal inline exhaust fan in a range of sizes.

IPX4  
Rated

Blauberg  
Motoren  
Motor

German  
Made

2  
Year

2 year  
replacement  
warranty

fanco

100:	EXVUV100
125:	EXVUV125
150:	EXVUV150B
200:	EXVUV200
250:	EXVUV250
315:	EXVUV315

Larger models  
require hardwiring

This fan can be used with the ESVURS1 speed controller.



## Dimensions (mm)

Model	100	125	150	200	250	315
D	98	123	149	198	248	314
D1	254	254	345	344	344	404
B	298	298	395	390	390	454
B1	258	258	355	350	350	414
L	205	205	200	240	249	260
L1	20	20	20	25	25	25
L2	25	25	20	29	31	40
L3	30	30	40	40	40	40

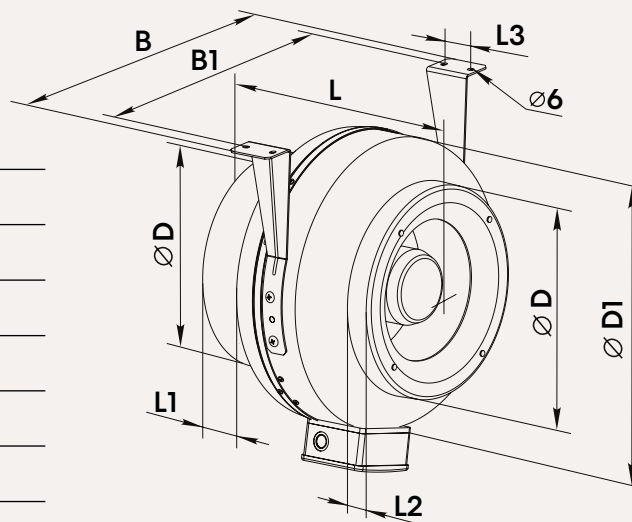

# VKM Series

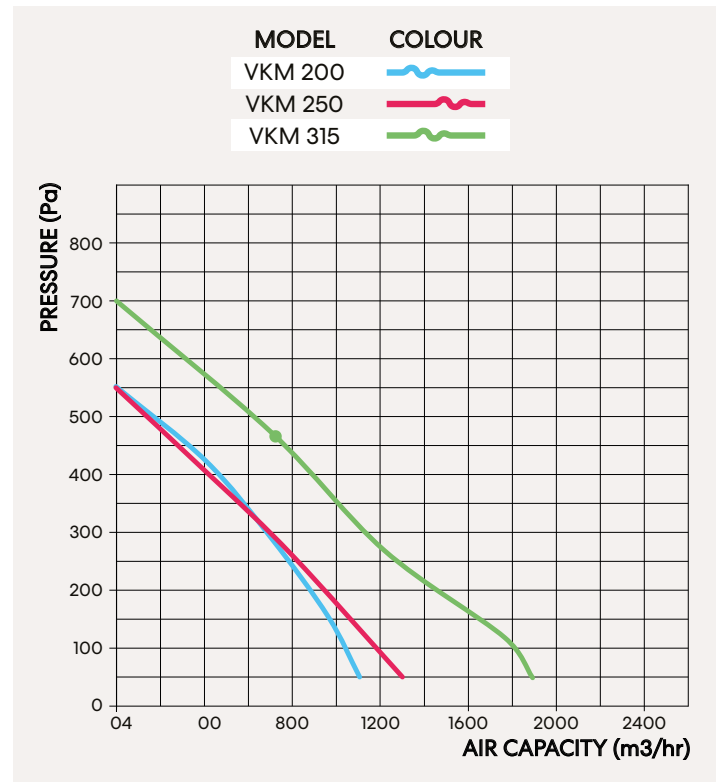
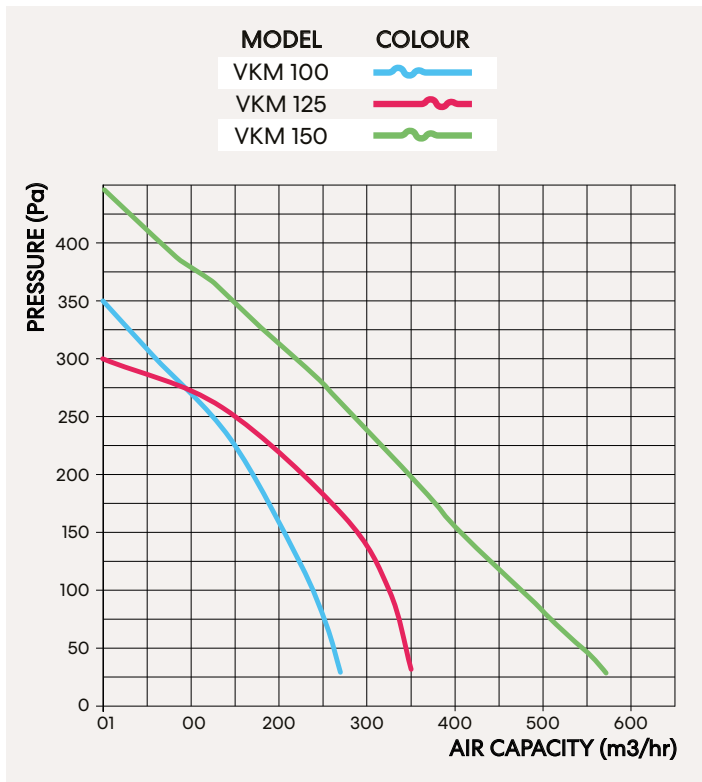

	100 Low / High	125 Low / High	150 Low / High	200 Low / High	250 Low / High	315 Low / High
<b>Voltage</b>	220 / 240	220 / 240	220 / 240	220 / 240	220 / 240	220 / 240
<b>Current (A)</b>	0.32	0.33	0.45	0.84	0.85	1.34
<b>Power (w)</b>	73	75	100	193	194	296
<b>Noise Level dB(A)</b>	47	47	45	45	52	54
<b>Capacity (m<sup>3</sup>/hr)</b>	270	355	580	1100	1310	1880
<b>Capacity (l/s)</b>	75.06	98.69	161.11	305.8	364.18	522.64
<b>Capacity (CFM)</b>	159.03	209.09	341.38	647.90	771.59	1107.32
<b>Duct Size (mm)</b>	100	125	150	200	250	315

Maximum temperature of transferred air 45°. The fan is designed for indoor application with the ambient temperature ranging from +1 °C up to +40 °C and relative humidity up to 80 %.