

# TT SILENT

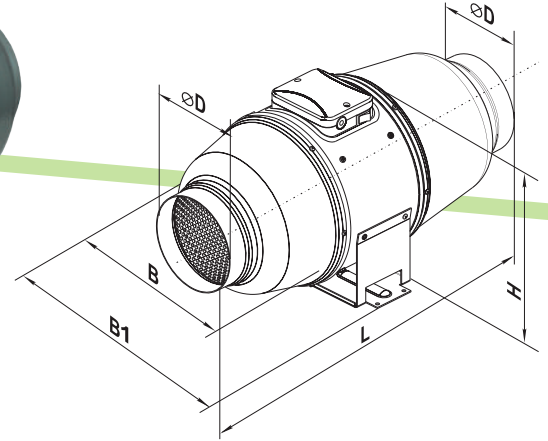

The Fanco TT series are designed for supply and exhaust ventilation of premises requiring high pressure and powerful airflow at a very low noise level. The fans are compatible with round duct with models in 150mm and 200mm.

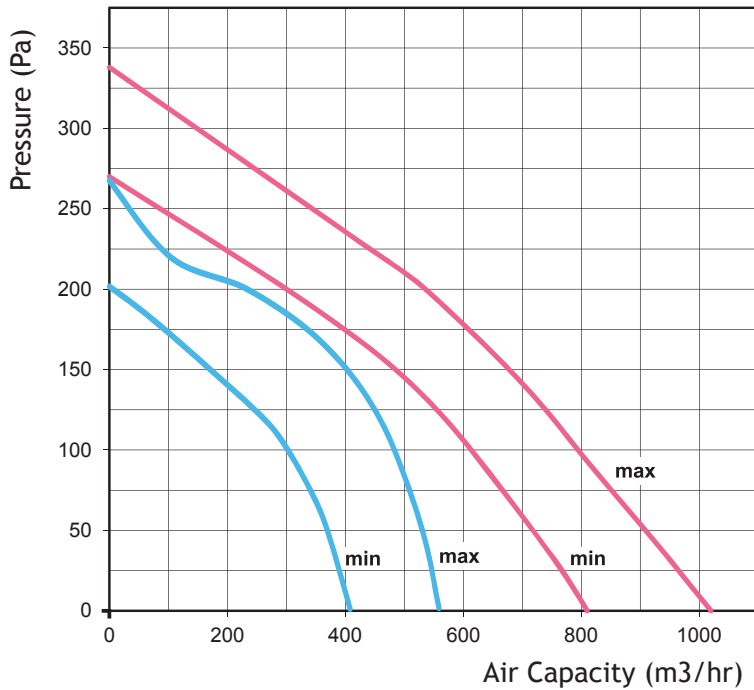

## DIMENSIONS

SKU	D	B	B1	L	H
EXVUTTS150	147	247	274	580	260
EXVUTTS200	198	293	386	550	295

SKU	EXVUTTS150		EXVUTTS200	
	Min	Max	Min	Max
Speed				
Voltage	230	230	230	230
Power (W)	45	52	78	110
Current (A)	0.2	0.23	0.35	0.49
Capacity (m3/hr)	405	555	810	1020
Capacity (l/s)	112.59	154.29	225.18	283.56
Capacity (CFM)	238.54	326.89	477.09	600.78
RPM (min-1)	1970	2645	2015	2445
Noise Level at 3m (dBA)	26	33	31	36
Max air temp (°C)	60	60	60	60
Protection rating	IPX4	IPX4	IPX4	IPX4